

**“PROBING THE PAUCITY OF WATER ABSORPTION IN  
REGULAR-TILLED ALKALI SOIL DUE TO PRESENCE  
OF SHALLOW CaCO<sub>3</sub> IMPERVIOUS LAYER (KANKAR)  
WITHIN THE CROP ROOT ZONE”**

**&**

***“Feasibility of Employing the Breakthrough Invention ‘Tilling  
Liner’ to address the problems”***

***(As referenced to Crop productivity Enhancement in Kunjpura,  
Karnal)***

**\*AKSHITA LATHAR, \*\*Dr. S. K. Kamra**

*\*\*Research Guide, Fellow (NAAS, INAE, Alexander von Humboldt)*

*Principal Scientist & Head, Div. of Irrigation and Drainage Engineering*

*Central Soil Salinity Research Institute – Karnal, Haryana, INDIA*

---

## **GRATITUDE**

Words are a remote medium of expression for thanks to my research mentor Dr. S.K. Kamra (Principal Scientist and Head, Division of Irrigation and Drainage Engineering at Central Soil Salinity Research Institute Karnal (CSSRI)), it being specially difficult for me to find words to express my deepest gratitude to him for believing in me and for all he has taught me.

During 2014, I got involved in above topic and came in contact with Dr. Kamra, at CSSRI. I was highly impressed not only with his scientific credentials but also for his humility and child like curiosity despite having made momentous contributions in developing and propagating subsurface drainage technology for the management of waterlogged saline soils across India.

The Robust technology of CSSRI involving application of gypsum for reclamation of alkali land was of interest to me since it dealt with problem, similar to the one we possessed. As such soils are highly dispersed and have poor water and air permeability, the plant growth in these soils is severely affected. This technology has been successfully employed by CSSRI in almost 2 million hectares in Haryana, Punjab and Uttar Pradesh.

The research work in summer was beauty in work, and strength of purpose, and co-operation. I am full of humility and gratitude for having participated so richly in it. The last two years have been the happiest and most productive of my life. I have been able, for the first time, to concentrate completely on my main research, with a glorious freedom from personal problems.

For your creative energy, your instinct for truth, your incredible contribution as a mentor, I give humble thanks. In devotion, and in gratitude.....

## ABSTRACT

*The present disclosure discloses a method of improving the soil structure of alkaline land by tilling with tilling liner having an upper arm and at least one tiller blade near bottom end, and an adjustable channel positioned on the upper arm of the tilling liner; inserting the subsoil tiller blade of subsoiler into the land such that the bottom end extends into the subsoil layer of alkaline land; and driving the subsoil tiller blade through the alkaline land such that the tilling surface loosens the packed subsoil layer for infiltration of water.*

*The present disclosure also discloses a tilling liner for use in improving the soil structure of alkaline land which comprises a support frame; and at least one subsoiler mounted in front of the support frame, having an upper arm and a subsoil tiller blade at bottom end*

*The study was conducted on agricultural field having poorly drained silt clay loam soil and a long history of regular tillage at the same depth in Karnal (Haryana), India.*

## SCOPE OF RESEARCH

The present research endeavor pertains to the study of the paucity of water absorption, as is found to be endemic, to vast stretch hectares of land in the Kunjpura region of Karnal district/ country-side in the north Indian state of Haryana. The research study, has in it ambit, ample provisions of touching upon the crucial issues of regular tilled alkali soil, caused mainly due to presence of shallow calcium carbonate, and its linkage to the impervious layer (kankar) within the crop root zone. While an attempt will be made to find a feasible solution to the nagging problem of water absorption that completes negates and renders the 'Flood Irrigation' method redundant and defunct, the study will also go on to reflect on the possibilities of replicating any success, if at all arrived at, in the farmlands under our immediate scrutiny, to vast stretches of unclaimed and underutilized land that lie in the surrounding areas. The scope of study also invent an agriculture implement that can be gainfully employed the process.

## OBJECTIVE OF RESEARCH STUDY

### The objectives of this study is:

- To Estimate the positive impact of ‘Tilling Liner’ – a Breakthrough invention in ‘regular-tilled’ Alkali soil, having a shallow  $\text{CaCO}_3$  impervious layer (Kankar) with in crop root zone.
- To Estimate the effect of Tilling-Liner for the purpose of saving crops during rain/flood irrigation and crop yield enhancement.
- To Estimate the effect of Tilling Liner in reference to the crop yield enhancement in comparison to the previous year crop yield.
- To Estimate the effect of Tilling Liner by probing the paucity of water absorption in regular-tilled soil having a shallow  $\text{CaCO}_3$  impervious layer (Kankar).
- To study the impact of “ease of comfort” of Tilling-Liner with the existing tractors of 35-60 HP, majorly available in the region.

## GEOGRAPHICAL PARAMETER

Soil is a combination of solid mineral and organic particles and pore space. Besides solid minerals and organic particles pore space is the most important are as far as soil health is concerned. Pore space allows for air and water storage and movement in soils. Compaction squeezes the soil and, since soil does not get compressed, pore space is reduced.

As far as our soil health is concerned, these pores space might have been filled with micro solid soil particles and geo-chemical salt moved along with water due to our repeated habit of regular tilling from last 50 years.

- To study the reasons responsible for formation of such a nature of soil
  - a. Geo-chemical mobility of salts plays a major role in formation of the  $\text{CaCO}_3$  (Kankar) layer
  - b. Reasons responsible for low absorption of water matter characteristic of soil. The fields being on or close to the changed pathway of River Yamuna. The continuous flow of water containing fine clay particles to develop heavy texture soils in river beds over a long time from spanning centuries

- c. The regular-tilling practice for the longer time leads to migrate the finest particles of soil (clay) downward, accumulate and bind, creating a very dense concrete layer of calcium carbonate.
- d. Whether, use of heavy machinery in the field for longer time is responsible for creating the calcium carbonate layer resulting low water absorption in the soil.
- e. Repeated cultivation of rice-wheat crops using same tillage mechanically over 30-50 years could has also contributed in formulating some sort of sub surface barrier at shallow depth.

As no penetrometer is available with us, the thorough test of soil at different depth is conducted at CSSRI Lab Karnal, to find out the nature of soil at different depth levels.

Our geographical parameter and study objective is widely different from the research concluded in various part of the world related to the similar problem of low water absorption. Secondly, regular-tilled alkali soil having no history of heavy machinery used in the past.

## RESEARCH METHODOLOGY

### a) Field Survey Observations

After a number of meetings and discussion with Dr. Kamra, we all concluded that the problem did not relate to surface (10- 15 cm) soil layer, on which we were focusing, since its high pH would have been definitely reduced by repeated addition of gypsum. Dr. Kamra hypothesized 3 possible reasons for surface stagnation and slow absorption of water to (i) creation of a subsurface clay layer at about 30 cm depth due to prolonged application of irrigation water containing finer sediments and pulverization due to repeated tillage, (ii) field being on or close to the changed pathway of river *Yamuna* passing in the area and (iii) existence of a  $\text{CaCO}_3$  *kankar* layer at shallower depth than at usually prevalent depth of 60- 90 cm in most reclaimed alkali soil areas. Each of the above three processes are likely to lead to creation of saturated soil moisture conditions in the shallow crop root zone due to prevention/ retardation of deep percolation losses and eventual crop failure due to aeration problem. Repeated cultivation of rice- wheat crops using same tillage machinery over 30- 50 year period could have also contributed in formulating some sort of subsurface barrier at shallow depth. (ILLUSTRATION - 1)

### b) Field survey and Sample Collection

To identify the exact reason and nature of problem, Dr. Kamra suggested and guide collection of soil samples up to 1.2 m depth from our field and studies the texture, depth and extent of  $\text{CaCO}_3$  layer as well as other chemical properties through laboratory analysis at CSSRI. In addition, water samples being used for irrigation were also to be collected to study if excess alkalinity (Residual Sodium Carbonate, RSC), known to reduce soil permeability, was the causative factor for slow absorption of water. Accordingly depth wise 18 soil samples from different horizons up to 1.2 m depth from 4 sites

in our fields and 2 water samples were collected under supervision of Mr. Abhishek Ramesh, Senior Research Fellow, working with Dr. Kamra. I was involved diligently in collection of these samples and moderately in analysis of different soil and water parameters in CSSRI laboratories, some of which involved procedures quite complex to my understanding. The analyzed soil and water parameters, methodologies adopted and units are summarized in Table 1. (**ILLUSTRATION – II**)

### c) Data Collection, Analysis and Findings

**Table1:** Soil and water parameters estimated in CSSRI laboratories

Soil / water	Parameter	Units	Methodology	No of soil/ water samples	Reference
Soil	Texture	% (sand, silt, clay fraction)	International Pipette method	13	Piper (1966)
Soil	CaCO <sub>3</sub>	%	Weighing % fraction of CaCO <sub>3</sub> particles > 2 mesh sieve size in soil	18	Standard weighing in lab
Soil and water	pH	Number	Using standard pH meter	18, 2	Jackson (1958)
Soil and water	EC	dS/m	Using standard Electrical Conductivity meter	18,2	Richards (1954)
	<b>Cations</b>				
Soil and water	Na <sup>+</sup>	meq/l	Flame photometer	18, 2	Richards (1954)
Soil and water	K <sup>+</sup>	meq/l	Flame photometer	18,2	Richards (1954)
Soil and water	Ca <sup>2+</sup> +Mg <sup>2+</sup>	meq/l	Titrimetric analysis using EBT indicator	18,2	Richards (1954)
	<b>Anions</b>				
Soil and water	Cl <sup>-</sup>	meq/l	Titration against AgNO <sub>3</sub> using potassium chromate as indicator	18,2	Richards (1954)
Soil and water	CO <sub>3</sub> <sup>2-</sup>	meq/l	Titrimetric analysis using phenolphthalein indicator	18,2	Richards (1954)
Soil and water	HCO <sub>3</sub> <sup>-</sup>	meq/l	Titrimetric analysis using methyl orange indicator	18,2	Richards (1954)

**Piper CS (1966) Soil and Plant Analysis. Hans Publisher, Bombay**

Jackson, M.L. (1958). *Soil Chemical Analysis*. Prentice-Hall, Englewood Cliffs, NJ, USA.

Richards, L.A. (1954). *Diagnosis and Improvement of Saline Alkali Soils*. USDA. Handbook No. 60. Washington, D.C.

In conformity with universal scientific conventions, soil parameters were determined for saturation extract of each soil sample obtained from soil water paste using standard suction methodology. Percent CaCO<sub>3</sub> fraction in different depth horizons was obtained by sieving and determining the amount larger than 2 mesh size in a known amount of dried soil sample. From ionic composition, soil quality parameter of sodium adsorption ratio (SAR) and water quality parameter of residual sodium carbonate (RSC) were derived by following equations: (ILLUSTRATION - 3)

$$SAR = Na / \{ (Ca + Mg) / 2 \}^{1/2}$$

$$RSC = [(CO_3 + HCO_3) - (Ca + Mg)]$$

Results on chemical analysis of soil and water relevant for this study are summarized in Table 2a, 2b, 2c.

**Table 2a:** Textural classification of soil profiles of study field

S. N.	Soil profile	Depth (cm)	Sand %	Silt %	Clay %	Textural class
1	S1 (Latitude: 29°42'49.0"N; Longitude: 76°03'17.9 "E)	0-15	19.2	45.9	34.9	Silt Clay Loam
2		15-30	20.1	44.7	35.2	Silt Clay Loam
3		30-60	20.0	59.3	20.7	Silt Loam
4		60-90	38.4	33.6	28.0	Clay Loam
5		90-120	20.2	55.0	24.8	Silt Loam
6	S2 (Latitude: 29°42'50.3"N; Longitude: 76°03'17.2"E)	0-15	20.3	64.2	15.5	Silt Loam
7		15-30	20.1	60.3	19.6	Silt Loam
8		30-60	19.9	60.1	20.0	Silt Loam
9		60-90	20.0	60.2	19.8	Silt Loam
10	S3 (Latitude: 29°42'51.7"N; Longitude: 76°03'18.2"E)	0-15	20.5	40.2	39.3	Silty Clay
11		15-30	20.1	40.3	39.6	Silty Clay
12		30-60	19.8	55.1	25.1	Silt Loam
13		60-90	37.1	38.4	24.5	Loam

**Table 2b:** Chemical and CaCO<sub>3</sub> analysis of soil samples at study field (2014)

S. N.	Soil Profile	Depth (cm)	EC <sub>e</sub> * (dS/m)	pH <sub>e</sub> *	SAR <sup>#</sup>	CaCO <sub>3</sub> %
1	S1	0-15	08.4	8.74	69.58	03.99
2		15-30	04.0	8.67	48.46	07.94
3		30-60	3.47	8.94	46.96	12.34
4		60-90	2.41	8.91	31.69	12.48
5		90-120	5.47	8.31	38.36	07.87

6	S2	0-15	4.05	8.50	06.58	06.49
7		15-30	2.36	9.13	09.34	04.68
8		30-60	1.75	8.12	09.50	09.10
9		60-90	1.63	8.78	08.62	14.81
10	S3	0-15	3.76	8.79	20.67	06.13
11		15-30	2.98	8.67	24.41	10.96
12		30-60	2.20	8.92	19.93	16.65
13		60-90	2.22	9.04	22.72	14.55
14	S4	0-15	3.34	9.05	10.14	09.05
15		15-30	2.66	8.88	14.17	15.49
16		30-60	2.85	8.86	22.51	19.34
17		60-90	2.94	8.37	32.48	16.20
18		90-120	2.37	8.12	11.51	08.35

\*Subscript e to a variable means saturated extract of soil; <sup>#</sup>SAR:  $\text{Na} / \sqrt{\{(\text{Ca} + \text{Mg})/2\}}$ ; all units in meq/l.

**Table 2c:** Chemical analysis of groundwater samples used for irrigation at study field (2014)

Tubewell / depth	EC (dS/m)	pH	Ca+Mg (meq/l)	CO <sub>3</sub> (meq/l)	HCO <sub>3</sub> (meq/l)	Cl (meq/l)	Na (meq/l)	K (meq/l)	RSC (meq/l)
Tubewell 1 (350 ft)	0.97	7.92	10.0	1.84	8.74	3.92	6.04	0.06	0.58
Tubewell 2 (450 ft)	0.71	8.70	5.5	1.84	6.44	2.45	6.96	0.03	2.78

#### d) Observations

From critical examination of physical and chemical characteristics of soil and water, the following observations can be made:

- Silt clay loam, silt loam, clay loam and loam texture of soil up to 1.2 m depth, representing 61.6-80.8 % slit + clay fractions (Table 2a), indicate heavy soils which have very slow water absorption but high moisture retention capacity. Since such soils are not typical of majority of soils in Karnal district or even Haryana, there are strong possibilities of these fields being on an earlier pathway of *Yamuna* River. Continuous flow of water containing fine clay particles are known to develop heavy texture soils in river beds over a long time frames spanning centuries.
- Un-reclaimed alkali soils in Karnal district were characterized by very high pH of more than 10.0 in surface layers and more than 9.0 in subsurface layers up to 1 m depth. Reclamation of such soils with gypsum application reduces gradually to favorable pH of 8.0- 8.5 in surface layers and only marginal reduction of pH in subsurface layers. The current status of pH and SAR in the

study field (Table 2b) indicate original alkali soils reclaimed marginally with application of gypsum

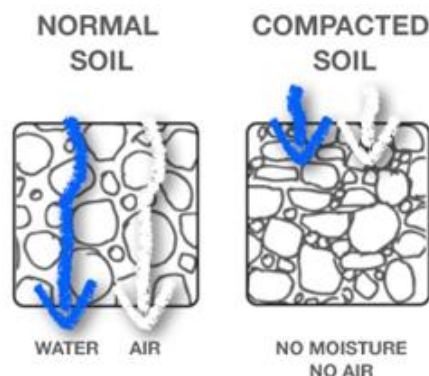

- (c) The original alkali soil in the study field would have been reclaimed fully, as in other areas in Karnal district but for the presence of  $\text{CaCO}_3$  hard *kankar* layer at much shallower depths. In 2 out of 4 soil profiles (S3 and S4, Table 2b) at study field, 10 to 20 % of the soil mass is contributed by  $\text{CaCO}_3$  in almost whole 1 m profile including surface layers, while remaining 2 profiles also indicate high calcite fractions below 30 cm depth.
- (d) Shallow presence of  $\text{CaCO}_3$  layer is the main causative factor for inefficient impact of gypsum application in reclamation of alkali soils in the study field. A shallow calcite horizon reduces soil depth for root spread and has low nutrient reserve and water storage capacity. Non-leaching of salts and excessive moist soil conditions due to presence of shallow  $\text{CaCO}_3$  layer are expected to lead to development of high salinity ( $\text{EC}_e > 4.0$  dS/m) in the surface layers, especially during high evaporative summer conditions as also observed in study field (Table 2b).
- (e) Though water quality of Tubewell 1 (Table 2c) is quite good with EC less than threshold water salinity of 2.0 dS/m and RSC less than threshold 2.5 for irrigation water, the RSC of Tubewell 2 (2.78) is slightly higher than threshold 2.5. Long term use of water of Tubewell 2 is likely to expound alkali soil conditions and will require repeated addition of gypsum in applied irrigation water.

The permanent solution to the problem of shallow  $\text{CaCO}_3$  layer was perceived by breaking it to create favorable environment for reducing soil pH with gypsum, salt leaching below root zone and optimal aeration. Dr. Kamra informed that CSSRI has developed an auger hole technique using tractor driven augers of 20- 25 cm diameter and 120 to 150 cm depth for planting trees in reclaimed alkali soils. These augers are made to pierce through the hard  $\text{CaCO}_3$  layer located at 60-90 cm depth which acts as a physical impediment for penetration of tree roots. These holes are filled with a standard mixture comprising of drilled out soil, 3 Kg gypsum, 8 Kg farm yard manure and 10- 20 Kg rice husk or silt in each auger hole. It was suggested that something similar needs to be developed for breaking shallow  $\text{CaCO}_3$  layer in our fields keeping in mind 2 dissimilarities with auger hole tree



technology: (i) Tractor driven auger hole equipment was used to make large holes for trees at 2- 3 m inter row and plant to plant spacing, while the piercing of  $\text{CaCO}_3$  layer in our field was required to cover the whole field for growing closely spaced crops, (ii) piercing of  $\text{CaCO}_3$  layer was required at much shallower depth ( $< 0.4$  m) in our field as compared to those ( $> 0.6$  m) for tree plantations in other fields.

After discussion on the features of tractor operated tillage equipments available with us, it was confirmed that our disc harrow and tiller (cultivator) will not be able to effectively penetrate and pierce existing  $\text{CaCO}_3$  layer in our fields. These equipments are currently being utilized by us and other farmers for breaking the clods and to preparing a finer seed bed by smoothing out the rough parts of surface soil left after plowing operations. Disc harrows, consisting of a number of carbon steel boron discs of varying concavities connected to a rigid frame, finely break up the soil and refine and evenly distribute it over the entire working width to create a perfect seed bed. These also help to chop up unwanted weeds or crop residues and to loosen inter-row soils for better absorption of water. Tillers (cultivators) stir and pulverize the soil, either before planting to aerate the soil and prepare a smooth seedbed or to uproot and bury weeds in later stages. For four-wheel tractors they are usually attached by means of a three-point hitch and driven by a power take-off (PTO).

While the harrow disturbs the entire surface of the soil, cultivators are designed to till the soil in careful patterns, sparing the crop plants but disrupting the weeds. Cultivators are often similar in form to chisel plows, but are different in the sense that while cultivator teeth work near the surface, usually for weed control, the chisel plow shanks work deep beneath the surface for breaking up hard layers or hardpans. Both disc harrow and cultivators are highly recommended equipments used by most farmers since these not only improve crop yields but help in maintenance of soil structure and biodiversity due to non inversion of soil layers. These are also often used in combination with seed drills for carrying out tillage and seeding operations in a single pass to limit operating costs and prevent excessive soil compaction.

#### e) Analysis of Soil and Water Samples in ICAR-CSSRI, Lab

The collected water samples were analyzed by using standard methods to determine the chemical characteristics. The collected water samples were analyzed for electrical conductivity (EC), pH and major cations and anions. The pH and EC both were measured immediately by using portable meters. Calcium and Magnesium both were analyzed by Ethylene-Diamine-tetra-acetic acid (EDTA), titimetric method. Total alkalinity, carbonate and bicarbonate were estimated by using titimetric method. Sodium and Potassium were estimated by using flame photometer.

The analysis of  $\text{EC}_e$  and pH cations and anions for powdered air dried soil samples was done by saturation extract (Soil: water = 1:1) and suction pump process and later with same following procedure. Water samples were analyzed directly with same further following procedure.

Soil textural analysis of samples is done by International Pipette Method in ICAR-CSSRI lab, is described below in brief.

To determine the relative masses of sand, silt and clay in the soil sample (thus, the texture) the combined mass of silt plus clay in the first aliquot and the mass of clay in the second must be determined. Also, the initial total volume of suspension and aliquot volume must be known. Pipetting a known fraction of suspension to an evaporating dish and boiling off the water is all that is done beyond dispersing the soil sample in water. **(ILLUSTRATION - 4)**

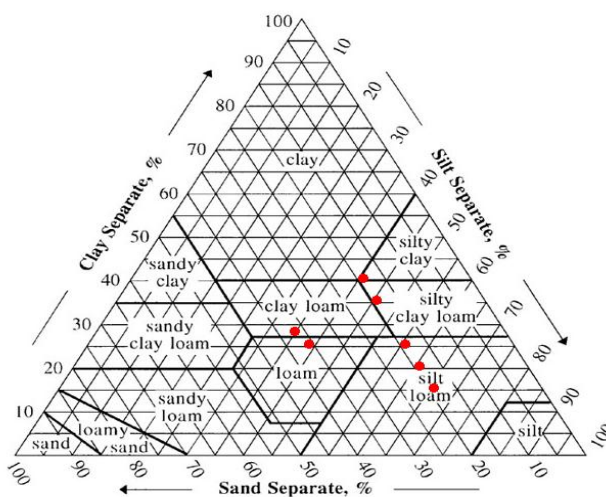

## TILLING LINER – A BREAKTHROUGH INVENTION (EQUIPMENT DESIGN DETAILS)

I was assigned the job to design equipment which should be able to not only plough the surface soil but also be able to pierce the  $\text{CaCO}_3$  layer. The ideas of purchasing a chisel plow or sub-soiler were also treated as last options considering heavy cost of these implements and a new high horsepower tractor needed to operate these implements. Accordingly, it was decided to initially attempt to make alterations in the available implements to be operated with our existing 60 HP tractor. Out of the disc harrow and cultivator available with us, the later seemed a better viable option. I along with my father critically observed the features and operation of our tractor driven cultivator (tiller).

The features of our existing tiller are summarized below:

- Working depth : 200- 250 mm
- No. Of tine : 9 (in 2 rows)
- Working width : 1750 mm
- Matched power tractor : 60 HP

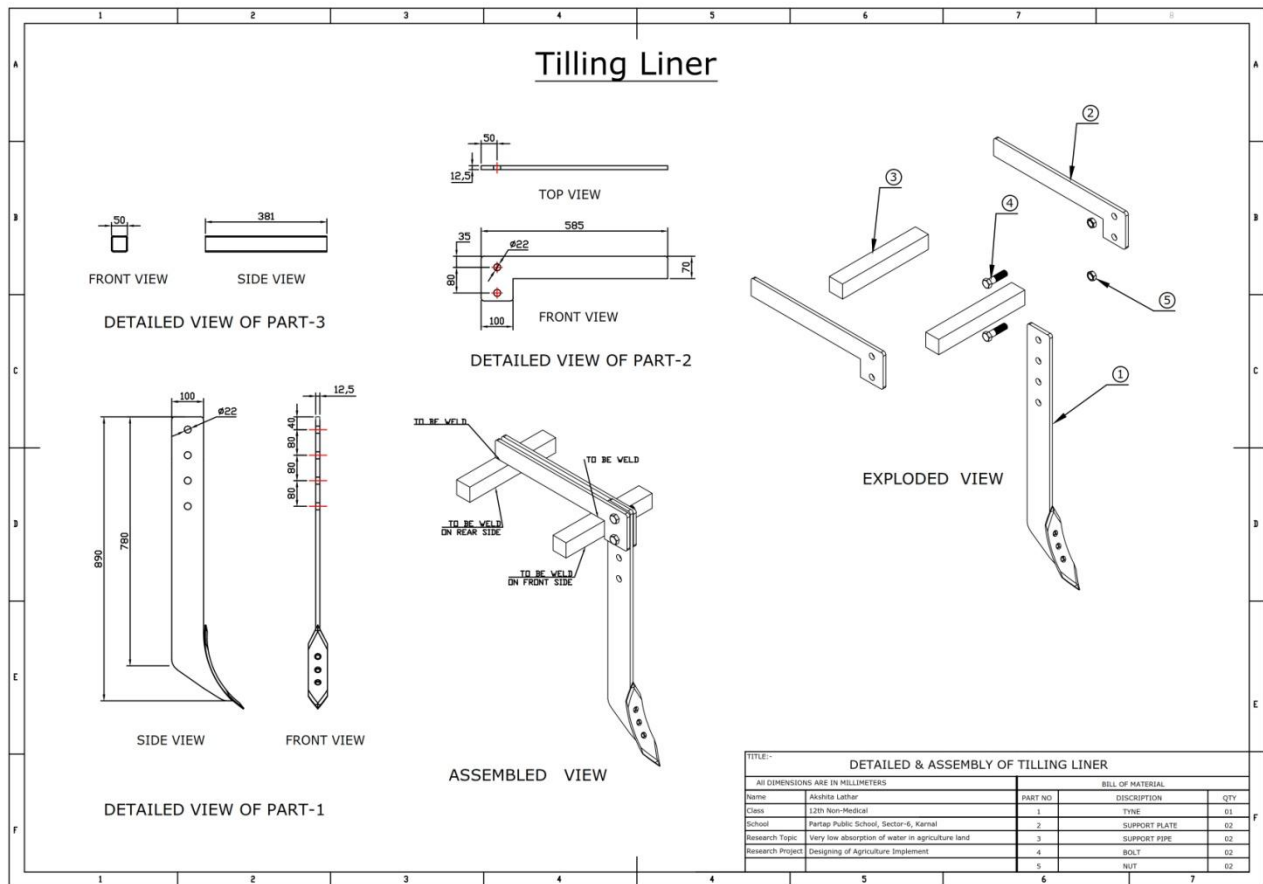

In the initial phase, I decided to make an independent tine of about 900 mm length to facilitate the tilling of soil up to 600 mm depth and the new tine was to be fixed with the existing tiller/cultivator to break the hard Calcium Carbonate layer without disturbing the upper fertile soil layer. Considering the heavy (clayey) soil texture in the area, it was presumed that operation of deeper tines will not only break the hard pan and will also lead to the formation of a sort of subsoil drain for absorption of water, similar to mole drains being used by Dr. Kamra's group for management of waterlogged heavy textured soils (called *Vertisols*) in western and southern India. It was expected that the improved soil drainage will reduce the stagnation of standing water in the fields during heavy rains or flood irrigation and ultimately improve crop yields. (ILLUSTRATION – V)

## RESEARCH FINDINGS

Accordingly the existing tiller was taken to a workshop near our farm in a sub town *Nilokheri* and I asked the mechanic to make an independent tine of about 900 mm length to facilitate the tilling of soil upto 600 mm depth. The new tine was to be fixed with the existing tiller and workable with existing tractor to control the tilling depth. The innovative agricultural tool 'Tilling Liner' was ready for field trials in 3 months and we used it first time during paddy season of year 2014. It was used for creating temporary subsoil drains in the field at certain depths and at certain distances. For best results from the machine, it was required to optimize the depth and spacing between two tilling lines for which a series of field trials were undertaken:

- (i) First we kept the depth of tine at 450 mm (1½ ft) and ploughed one of the fields just before the paddy season (July- October). This trial gave us good results since the field started absorbing water at such quick rates that it became a challenge for us to retain water in field. I remember that we had to provide more than 20 irrigations of 75 to 100 mm each, amounting to considerable load on groundwater resources. It was quite irritating and frustrating to listen to jostling and repeated funny remarks of neighboring farmers. We learnt a lesson from our first trial of not ploughing the field with the designed equipment before paddy crop as continuous water retention is necessary during the initial period of paddy crop. Till the time of harvesting of crop, repeated irrigation cost us heavily.
- (ii) Now it was decided to use the equipment at 450 mm depth before sowing the wheat crop. The results were encouraging since the land started absorbing the water at a faster rate than before. During the next wheat sowing time, the tilling depth was increased to 600 mm to further improve the water absorption capacity of the field. The results were promising as the absorption rate increased considerably leading to better crop yields and income in comparison to the earlier times. A good rain occurred just before the harvesting time of wheat crop which would have caused considerable loss had the adsorption rate been slow. However, the rainfall water was absorbed within 5 days in comparison to the earlier absorption time of 15 days or more for similar rainfall events.
- (iii) The results over the past 2 years have confirmed the effectiveness of Tilling Liner in improving the absorption capacity of soils leading to significant improvement in rice and wheat yields and enhanced prosperity in our family. To tackle the challenge of quick absorption of water during initial phases of wheat crop, increasing the equipment operation distance from 1.5 m to 5 m proved highly effective as the number of created temporary drains got reduced.
- (iv) Further, we have found that repeated piercing of hard pan is not required and accordingly we now use this method only in wheat and not in paddy. The intervening period between wheat and paddy crop slows down the water absorption capacity of soil resulting in reduced percolation

losses during paddy season. Specific observations on the use of Tilling Liner in wheat crop are as follows:

- After first irrigation, 20 days after sowing of seeds, the leaf of wheat crop did not turn yellowish as was the scenario in earlier years.
- We applied 4- 5 irrigations in comparison to one irrigation earlier leading to a very healthy crop and significantly higher crop yields.
- Before harvesting of wheat in March end, usually there is usually a heavy rainfall which can adversely affect crop yield if not drained or absorbed quickly. After using the Tilling Liner, the water gets absorbed with 3-4 days in comparison to earlier span of 15 days or more. Earlier such a rain was called culprit rain but now it is like a normal happening as it is not affecting us.
- Finally the wheat yield we got from that field was 18- 25 quintals per acre of good quality grain, almost 2-3 times of earlier 8- 10 quintal per acre yield, that too of relatively low quality grain.

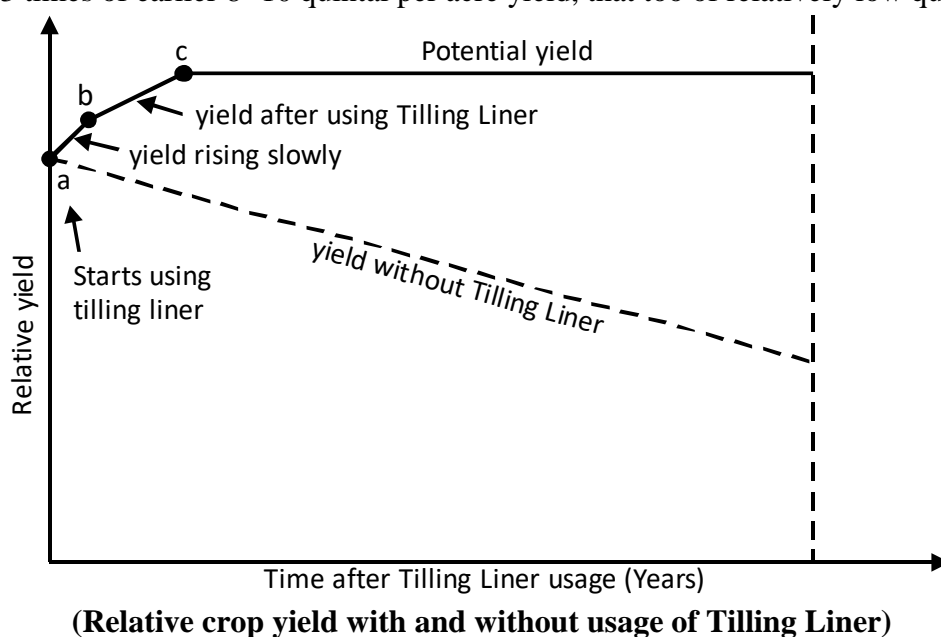

## CONCLUSION AND FURTHER SCOPE OF RESEARCH

### Probable reasons for the shallow $\text{CaCO}_3$ layer

- Regular tilled Alkali soil for years at same depth
- No heavy machinery used in the field for a longer time
- Geo-chemical mobility of salts leads to formation of the  $\text{CaCO}_3$  concrete layer (Kankar).
- Only one time can be attached to the existing cultivator as majority of the tractors available with farmers ranges 35-55 HP

**TILLING-LINER V/S SUB-SOILER**

Activity	Tilling-Liner	Sub-Soiler	Merits of Tilling-Liner
Independent Agriculture Equipment	NO	YES	No separate inventory and maintenance cost
Flexibility of using with existing Agriculture Equipment	YES	NO	Ease of operation
Cultivation depth control of soil	Fully	Partial	100% Flexibility of operation
Disturbance to top fertile surface of soil	Minimum	Major	Contributes to crop yield enhancement
Type of Tractor required for operation	Two Wheeled	Majorly Four Wheeled	Required low cost & use of existing tractor
Tractor HP Range required for operation	35-60 HP	60-250 HP	Low cost of equipment required for operation
Equipment cost	Less than 100\$	More than ____	Minimum cost equipment

**REFERENCES**

Pennstate Extension – Soil Compaction and Conservation Tillage

<http://extension.psu.edu/plants/crops/soil-management/conservation-tillage/soil-compaction-and-conservation-tillage>

University of Georgia – What Size Farm Tractor Do I Need (Paul E. Sumner and E. Jay Williams)

<http://caes2.caes.uga.edu/engineering/pubs/documents/farm%20tractor.pdf>.

Subsoiler

<http://www.clemens-america.com/index.EN.php?cnt=p4010&nav=m207&dash=tiefenlockerer>

Ohio State Study – The Benefits of Subsoiling

<https://www.no-tillfarmer.com/articles/3861-the-benefits-of-subsoiling>

Ohio State research – "Break It Up: Subsoiling Study Eyes Winter Tillage"

<http://ieassa.org/en/break-it-up-subsoiling-study-eyes-winter-tillage/>

University of Minnesota – Soil compaction: causes, effects and control

<http://www.extension.umn.edu/agriculture/tillage/soil-compaction/#causes>

## ANNEXURE

### ILLUSTRATION – I



Ill crop Health cause due to poor drainage in Alkali Soil – Kunjpura Field Observation

### ILLUSTRATION – II





Physical Field Survey in the Neighboring field to access the poor drainage nature of soil



**ILLUSTRATION – III**



Soil sample collection from the field





Soil sample testing at Central Soil Salinity Research Institute, Karnal

**ILLUSTRATION – IV**





Innovative Agriculture Tool “**Tilling Liner**”